

ANT COLONY ALGORITHMS FOR NONLINEAR ANALYSIS AND OPTIMAL DESIGN OF STRUCTURES

A. Kaveh^{*,†} and M. Hassani

Centre of Excellence for Fundamental Studies in Structural Engineering, Iran University of Science and Technology, Narmak, Tehran-16, Iran

ABSTRACT

In this paper nonlinear analysis of structures are performed considering material and geometric nonlinearity using force method and energy concepts. For this purpose, the complementary energy of the structure is minimized using ant colony algorithms. Considering the energy term next to the weight of the structure, optimal design of structures is performed. The first part of this paper contains the formulation of the complementary energy of truss and frame structures for the purpose of linear analysis. In the second part material and geometric nonlinearity of structure is considered using Ramberg-Osgood relationships. In the last part optimal simultaneous analysis and design of structure is studied. In each part, the efficiency of the methods is illustrated by means simple examples.

Received: 5 July 2011, Accepted: 28 December 2011

KEY WORDS: Force method; continuous ant colony optimization; nonlinear analysis; design; optimization; material and geometric nonlinearity; simultaneous analysis and design of structures

1. INTRODUCTION

Problems in structural mechanics have, for a long time, been solved using linear or linearized equations representing their behavior. The solutions obtained based on these linear models were considered adequate for many practical and engineering purposes although it was recognized that linearized equations provide no more than a first approximation to the actual situations. It is often recognized that there is an increasing demand for more realistic models to

* Corresponding author: A. Kaveh, Centre of Excellence for Fundamental Studies in Structural Engineering, Iran University of Science and Technology, Narmak, Tehran-16, Iran

†E-mail addressalikaveh@iust.ac.ir

predict the responses of actual structures. Such demands combined with the availability of superior computational facilities have enabled the researchers to abandon the linear theories in favor of nonlinear methods of solution.

Nonlinearities in structures can arise in many different ways. The generalized Hook's law is not valid if the material stress-strain behavior is nonlinear. This type of nonlinearity is generally known as material or physical nonlinearity. Alternatively, a different type of nonlinearity based on the deformations of an elastic body is possible in many instances. Problems involving deformations that are large are called geometrically nonlinear problems. Here minimization of the complementary energy transforms material nonlinearity to nonlinear system of equations, which can be solved using the Newton or Modified Newton-Raphson methods. One can alternatively use differential concepts for the solution of such problems. This will then lead to a system of ordinary nonlinear differential equations. These equations become more involved when geometric nonlinearity is also included. In such a case one has to use iterative methods. In this paper, an ant colony algorithm used to avoid the formation of the nonlinear equations. The energy concepts are important tools for the solution of nonlinear problems which are presented in subsequent sections. Recent formulations which are different from the existing approaches (see Refs. [1,2]) lead to better results and allows the analysis and design to be performed simultaneously more efficiently. Another important application of this formulation is to reach a specified level of stress ratio for the elements of the structures. It will be seen that for optimal design considering the weight term next to the energy term, the search in the ant colony algorithm can be directed to achieve the least possible weight for the structures.

In the first part of this paper some new goal functions for the purpose of minimization of the complementary energy of the structure is introduced for linear analysis. In the second part material nonlinearity is studied using Ramberg-Osgood formulas. Third part contains the algorithms for geometric nonlinear analysis. In the last part simultaneous optimal design of structure is presented.

In this study a continuous ant colony optimization (CACO) algorithm is used based on the algorithm introduced in Ref. [3] for the purpose of minimization of the complementary energy function. For more information on discrete and continuous ant colony algorithms one can refer to Refs. [4-7].

Examples from literature are studied in order to illustrate the capability of the present approaches.

2. LINEAR ANALYSIS BY FORCE METHOD AND ANT COLONY ALGORITHM

In this section, a matrix formulation using the basic tools for structural analysis - equilibrium, compatibility and load-displacement relationships - is described. For the nonlinear material the stress-strain relationship can be expressed as $\epsilon = f(\sigma)$ or $\sigma = g(\epsilon)$. Then the strain energy and complementary energy can be written as

$$U = \iint g(\epsilon) d\epsilon dV \quad \text{and} \quad U^c = \iint f(\sigma) d\sigma dV \quad (1)$$

U is the strain energy and U^c is the complementary energy of the structure and are shown in Figure 1 in linear and nonlinear materials. For truss structures substituting $V = AL$, one of the integrals will be omitted. The total potential energy can be expressed as

$$V = U - \mathbf{P}^t \mathbf{u} \tag{2}$$

where \mathbf{P} is the vector of external loads and \mathbf{u} is the vector of joint displacements. Considering the Castigliano's theorem for a linear or materially nonlinear structure, the total potential energy become stationary for equilibrium state. Similarly, from the second theorem of Castigliano, the complementary energy becomes stationary for compatible state of internal forces.

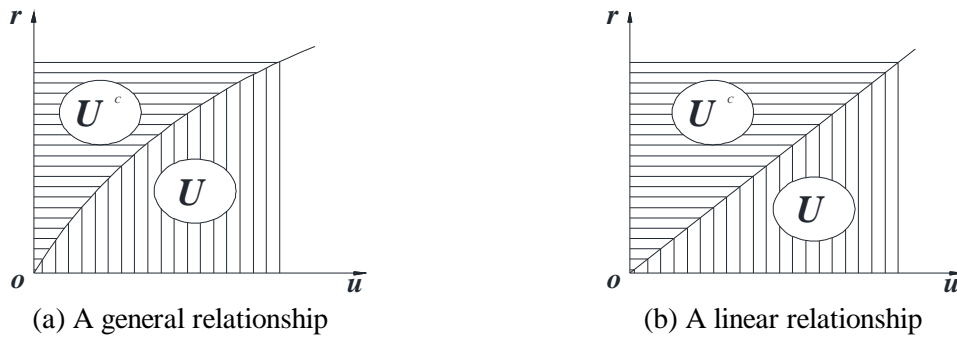

Figure 1. Force-displacement relationship

The main aim is to formulate the energy function of a structure and minimize this function using the ant colony algorithm, while satisfying all stated compatibility conditions. The formulation is based on the minimum complementary work principle.

Suppose $\{\mathbf{p}\} = \{p_1, p_2, \dots, p_n\}^t$ is the vector of nodal forces, $\{\mathbf{q}\} = \{q_1, q_2, \dots, q_r\}^t$ contains r redundant forces, and $\{\mathbf{r}\} = \{r_1, r_2, \dots, r_m\}^t$ comprises of the internal forces of the members. Here, n is the number of nodal forces, r is the number of redundant forces and m is the number of internal forces. From equilibrium

$$\{\mathbf{r}\} = [\mathbf{B}_0] \{\mathbf{p}\} + [\mathbf{B}_1] \{\mathbf{q}\} = [\mathbf{B}_0 \quad \mathbf{B}_1] \begin{bmatrix} \mathbf{p} \\ \mathbf{q} \end{bmatrix} \tag{3}$$

In general, $[\mathbf{B}_0]$ and $[\mathbf{B}_1]$ can be specified by using equilibrium equations, therefore Equation (3) represents the equilibrium in the solution. $[\mathbf{B}_0]$ and $[\mathbf{B}_1]$ are rectangular matrices each having m rows with n and r columns. For example, if $p_i=1$ and all other nodal and redundant forces are equal to zero, internal forces of members are the entries of the i -th column of $[\mathbf{B}_0]$. Also if $r_i=1$ and all other forces are equal to zero, internal forces of members are the entries of the i -th column of $[\mathbf{B}_1]$.

In Equation (3), $\mathbf{B}_0 \mathbf{P}$ is known as a *particular solution*, which satisfies equilibrium with the imposed loads, and $\mathbf{B}_1 \mathbf{q}$ is a *complimentary solution*, formed from a maximal set of independent self-equilibriums stress systems.

From classical complementary energy concepts

$$U^c = \frac{1}{2} \{\mathbf{r}\}^t [\mathbf{F}_m] \{\mathbf{r}\} \quad (4)$$

where $[\mathbf{F}_m]$ is the unassembled flexibility matrix of the structure. Substituting $\{\mathbf{r}\}$ from Equation (3) in Equation (4) leads to

$$U^c = \frac{1}{2} \begin{bmatrix} \mathbf{p} \\ \mathbf{q} \end{bmatrix}^t [\mathbf{H}] \begin{bmatrix} \mathbf{p} \\ \mathbf{q} \end{bmatrix} \quad (5a)$$

Where

$$[\mathbf{H}] = [\mathbf{B}_0 \quad \mathbf{B}_1]^t [\mathbf{F}_m] [\mathbf{B}_0 \quad \mathbf{B}_1] \quad (5b)$$

Decomposing the matrix $[\mathbf{H}]$ into four submatrices $[\mathbf{H}_{qq}]$, $[\mathbf{H}_{qp}]$, $[\mathbf{H}_{pq}]$, and $[\mathbf{H}_{pp}]$, we obtain U^c as

$$U^c = \frac{1}{2} (\{\mathbf{p}\}^t [\mathbf{H}_{pp}] \{\mathbf{p}\} + \{\mathbf{p}\}^t [\mathbf{H}_{pq}] \{\mathbf{q}\} + \{\mathbf{q}\}^t [\mathbf{H}_{qp}] \{\mathbf{p}\} + \{\mathbf{q}\}^t [\mathbf{H}_{qq}] \{\mathbf{q}\}) \quad (6)$$

In the classical method, for the purpose of satisfying the compatibility condition, the derivative of U^c with respect to $\{\mathbf{q}\}$ is found and equated to zero, leading to

$$\{\mathbf{q}\} = -[\mathbf{H}_{qq}]^{-1} [\mathbf{H}_{qp}] \{\mathbf{p}\} \quad (7)$$

Since $[\mathbf{H}]$ is symmetric, therefore $[\mathbf{H}_{qp}]^t = [\mathbf{H}_{pq}]$.

In the present approach, finding the inverse of $[\mathbf{H}_{qq}]$ is not required. Instead, U^c from Equation (5a) is minimized by ant colony algorithm.

Here, we suggest a goal function as

$$F_U = \begin{bmatrix} \mathbf{p} \\ \mathbf{q} \end{bmatrix}^t [\mathbf{H}] \begin{bmatrix} \mathbf{p} \\ \mathbf{q} \end{bmatrix} \quad (8)$$

Or

$$F_U = \{\mathbf{p}\}^t [\mathbf{H}_{pp}] \{\mathbf{p}\} + \{\mathbf{q}\}^t [\mathbf{H}_{qp}] \{\mathbf{p}\} + \{\mathbf{p}\}^t [\mathbf{H}_{pq}] \{\mathbf{q}\} + \{\mathbf{q}\}^t [\mathbf{H}_{qq}] \{\mathbf{q}\} \quad (9)$$

for the purpose of finding redundant forces ($\{\mathbf{q}\}$). Instead of Equations (8) and (9) and considering Equation (7), a goal function can be introduced as

$$F_U = \text{norm}(\{\mathbf{H}_{qp}\} \{\mathbf{p}\} + [\mathbf{H}_{qq}] \{\mathbf{q}\}) \quad (10)$$

In Equations (8-10), $\{\mathbf{p}\}$, $[\mathbf{H}]$ and its submatrices are constant; therefore the ant colony algorithm will find the best results for $\{\mathbf{q}\}$ by minimizing the complementary energy function. Then the internal forces of the structure can be found using Equation (3).

Also we can use the general complementary energy function (Equation (4)) as the goal function of minimization. In this case, there is no need to calculate the $[H]$ and its submatrices. In order to minimize F_U , a continuous ant colony algorithm is employed. Evaporation is also added to the algorithm, introduced in Ref. [3], for improving the results.

Here we consider two examples, studied previously in Reference [1], using genetic algorithm.

2.1. Example 1

Consider the portal frame with constant EI for all the members as shown in Figure 2. The basic structure is constructed by imaginary cut at support node 5. The necessary matrices are as follows:

$$B_0 = \begin{bmatrix} 3 & 3 \\ 0 & 3 \\ 0 & 3 \\ 0 & 0 \\ 0 & 0 \\ 0 & 0 \\ 0 & 0 \\ 0 & 0 \end{bmatrix}, B_1 = \begin{bmatrix} 0 & -6 & 1 \\ 3 & -6 & 1 \\ 3 & -6 & 1 \\ 3 & -6 & 1 \\ 3 & -6 & 1 \\ 3 & 0 & 1 \\ 3 & 0 & 1 \\ 0 & 0 & 1 \end{bmatrix}, F = \frac{3}{6EI} \begin{bmatrix} 2 & 1 & 0 & 0 & 0 & 0 & 0 & 0 \\ 1 & 2 & 0 & 0 & 0 & 0 & 0 & 0 \\ 0 & 0 & 2 & 1 & 0 & 0 & 0 & 0 \\ 0 & 0 & 1 & 2 & 0 & 0 & 0 & 0 \\ 0 & 0 & 0 & 0 & 2 & 1 & 0 & 0 \\ 0 & 0 & 0 & 0 & 1 & 2 & 0 & 0 \\ 0 & 0 & 0 & 0 & 0 & 0 & 2 & 1 \\ 0 & 0 & 0 & 0 & 0 & 0 & 1 & 2 \end{bmatrix}$$

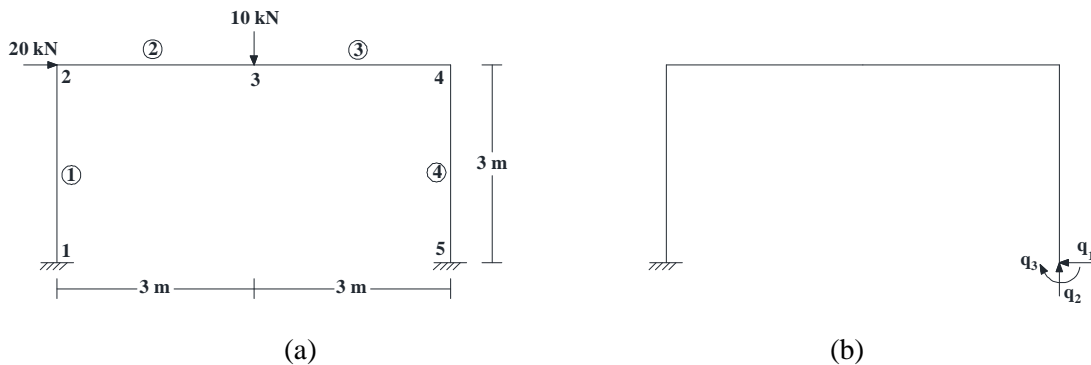

Figure 2. A portal frame: (a) A portal frame and its loading; and (b) The selected basic structure

EI in the formation of $[F]$ is taken as constant for all the members. Therefore it can be omitted from the calculation. Equation (8) is considered as the goal function. The variation of F_U versus the number of iterations is illustrated in Figure 3. Here, $\{q\}$ is calculated as $\{q\} = \{12.9232, 8.7035, -21.7221\}^t$ kN and from exact calculation $\{q\} = \{13.00, 8.75, -21.75\}^t$ kN is obtained. For the analysis of this structure the number of iterations is taken as 40 and each iterations consists of 35 ants.

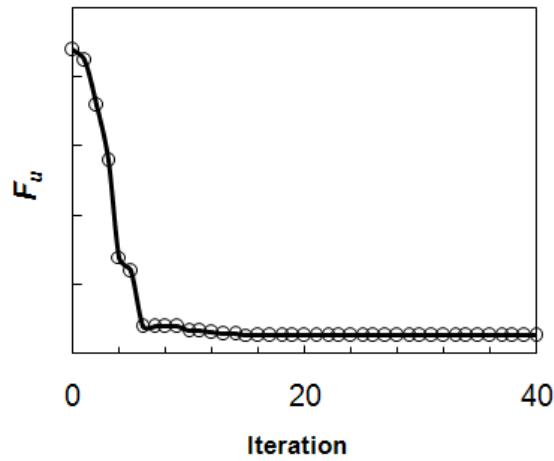

Figure 3. Variation of F_U versus the number of iterations.

2.2. Example 2

Consider the 10-member frame with constant EI and EA as shown in Figure 4. Diagonal members treated as frame members and have no connection with each other in the intersection. The selected basic structure is illustrated in Figure 5. In this case considering flexural and axial complementary energy is necessary for precise results therefore the total complementary energy of the structure is obtained from the summation of flexural and axial energy (the moment of inertia I is related to area A by $I=75A$). The exact F_U is calculated as $F_U = 3.86080 \times 10^6$ and from ant colony algorithm $F_U = 3.86095 \times 10^6$ is obtained. For this case, $\{\mathbf{q}\} = \{15.6, -38.1, -596.0, -36.0, -73.0, 1250.7, -61.4, 169.8, -238.0, -73.5, -669.8, 550.9, -72.3, 798.9, 90.3\}^t$ kN and from exact calculation $\{\mathbf{q}\} = \{15.8, -38.4, -590.8, -36.2, -69.1, 1245.7, -61.7, 175.1, -274.5, -72.8, -677.6, 574.1, -71.9, 794.2, 112.8\}^t$ kN is calculated.

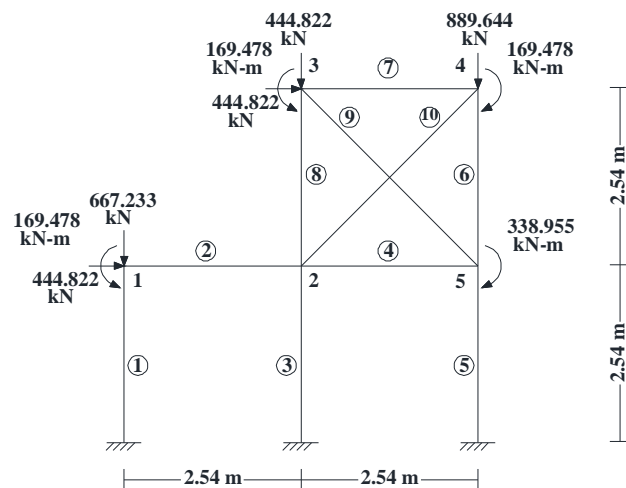

Figure 4. A 10-member frame with 15 degrees of static indeterminacy

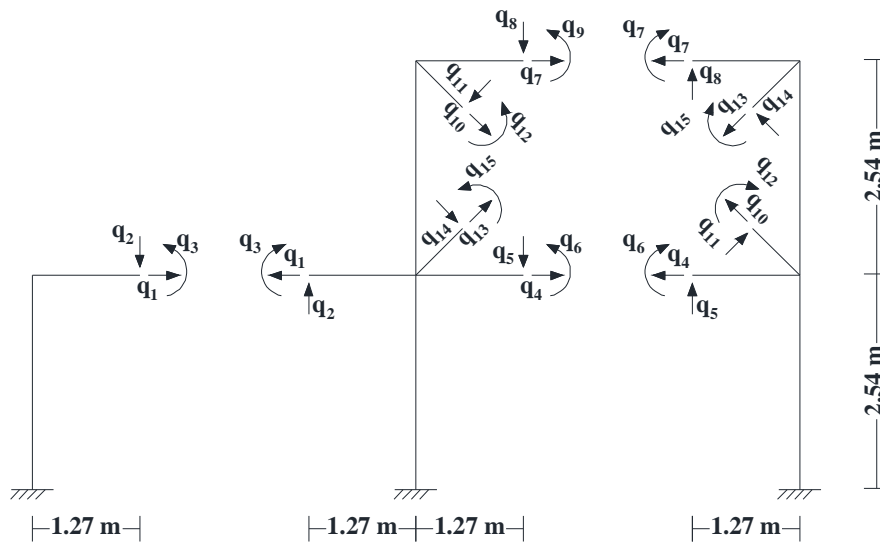

Figure 5. The selected basic structure for 10-member frame

3. MATERIAL NONLINEAR ANALYSIS USING ANT COLONY ALGORITHM

In this section, the material nonlinear analysis of structures is performed using the force method and ant colony algorithm. The main difference between linear and material nonlinear formulation of the complementary energy is due to different properties of the flexibility matrix. For materials with linear behavior, the flexibility matrix \mathbf{F} is independent of redundant forces \mathbf{q} , but for nonlinear materials it is dependent. Therefore, the existing linear stress-strain relationships can not be used in the nonlinear analysis of structure. Various functions are suggested for stress-strain relationship and one of the most well-known functions is the Ramberg-Osgood formula expressed as

$$\varepsilon = \frac{\sigma}{E} + \frac{3}{7} \frac{\sigma_0}{E} \left(\frac{\sigma}{\sigma_0} \right)^n \tag{11}$$

where E is the elastic modulus, σ_0 is the magnitude of stress at the point with tangential modulus equal to $0.7E$. The parameter “ n ” measures the steepness of the strain hardening part of the ε - σ diagram (known as the strain hardening index). Increasing n , the function gets closer to that of an elastic-plastic model.

Ant colony goal function is similar to the functions introduced for the linear analysis considering a different flexibility matrix in the material nonlinearity.

Force method and complementary energy concepts can be used indirectly for the material nonlinear analysis of structures, where a different new goal function for minimization using ant colony algorithm is introduced. In any type of structures, for the i -th member $e_i = F_i r_i$ or $\mathbf{e} = \mathbf{F} \mathbf{r}$, where e is the deformation and r is the internal force. U^c for the i -th member is

$$U^c = \int e_i^t dr_i \quad (12)$$

For a structure with m members

$$U^c = \sum_{i=1}^m \int_0^{\eta} e_i^t dr_i = \int_0^r \mathbf{e}^t dr = \int_0^r \mathbf{F}^t \mathbf{r} dr \quad (13)$$

For satisfying the compatibility condition, from classical force method

$$\frac{\partial U^c}{\partial \mathbf{q}} = 0 \rightarrow \frac{\partial U^c}{\partial \mathbf{r}} \times \frac{\partial \mathbf{r}}{\partial \mathbf{q}} = 0, \quad (14)$$

$$\frac{\partial U^c}{\partial \mathbf{r}} = \mathbf{F}^t \mathbf{r} \quad \text{and} \quad \frac{\partial \mathbf{r}}{\partial \mathbf{q}} = \mathbf{B}_1 \quad (15)$$

Therefore

$$\mathbf{B}_1^t \mathbf{F} \mathbf{r} = 0 \quad \text{leading to} \quad \mathbf{B}_1^t \mathbf{F} (\mathbf{B}_0 \mathbf{p} + \mathbf{B}_1 \mathbf{q}) = 0 \quad (16)$$

This method also results in \mathbf{q} . It can be seen that in this case we have a nonlinear equation; and for a general structure a set of nonlinear equations will be obtained. For solution one can use Newton's iterative method. The rate of convergence and uniqueness of the solution and the stability of convergence are the main issues. There are other methods available with their own difficulties. In order to overcome these difficulties, in this paper AC is employed turning $\mathbf{B}_1^t \mathbf{F} \mathbf{r}$ into zero. Redundant forces \mathbf{q} in the formation of $[\mathbf{F}]$, are considered as unknowns of the ant colony algorithm and then member forces are calculated using Equation (3). From Equation (16) it can easily be shown that instead of $\mathbf{B}_1^t \mathbf{F} \mathbf{r}$, one can turn $\mathbf{B}_1^t \mathbf{F}$ into zero for the purpose of finding redundant forces. Since this value is a vector and the result is exact when all its entries become zero; therefore, one can try to make the following to zero:

$$\mathbf{G} = \text{norm}(\mathbf{B}_1^t \mathbf{F}) \quad (17)$$

In Ref. [1], \mathbf{G} was introduced as $\mathbf{G} = (\mathbf{B}_1^t \mathbf{F})^t (\mathbf{B}_1^t \mathbf{F}) = \mathbf{F} \mathbf{B}_1 \mathbf{B}_1^t \mathbf{F}$. This value is a matrix with m rows and m columns, where m is the number of the members of structure and can not be turned into zero in some cases. However, Equation (17) leads to better results than other functions.

Here we consider two nonlinear examples with different stress-strain relationships. AC results are compared to those of genetic algorithm and it is shown that AC performs better in the nonlinear analysis of structures.

3.1. Example 1

A truss is considered as shown in Figure 6 with the stress-strain relationship as $\sigma^3 = 7\varepsilon/A^3$.

This truss has one degree of static indeterminacy; therefore the minimization goal function has only one unknown. With this redundant force, other member forces, \mathbf{r} , are obtained from

equilibrium (Equation (3)). Dividing these forces by the corresponding cross-sectional areas, result in the stresses. The stress-strain relationship leads to the strains, when multiplied by the member lengths, provides the elongation of the members, \mathbf{e} . Having the relation between \mathbf{e} and \mathbf{r} for i -th member, one can formulate \mathbf{F} as

$$[\mathbf{F}_i] = \frac{Lr^2}{7} \tag{18}$$

Employing $[\mathbf{B}_0]$, $[\mathbf{B}_1]$ and $[\mathbf{F}]$, the goal function for the minimization can be formulated (Equations (8-10) and (17)). AC leads to $\{\mathbf{r}\} = \{10.000, 10.000, 20.893, -20.000, -14.100, -9.459, -21.407\}^t$ kN where GA leads to $\{\mathbf{r}\} = \{10.002, 10.002, 20.682, -19.982, -14.105, -9.387, -21.691\}^t$ kN (Ref. [1]).

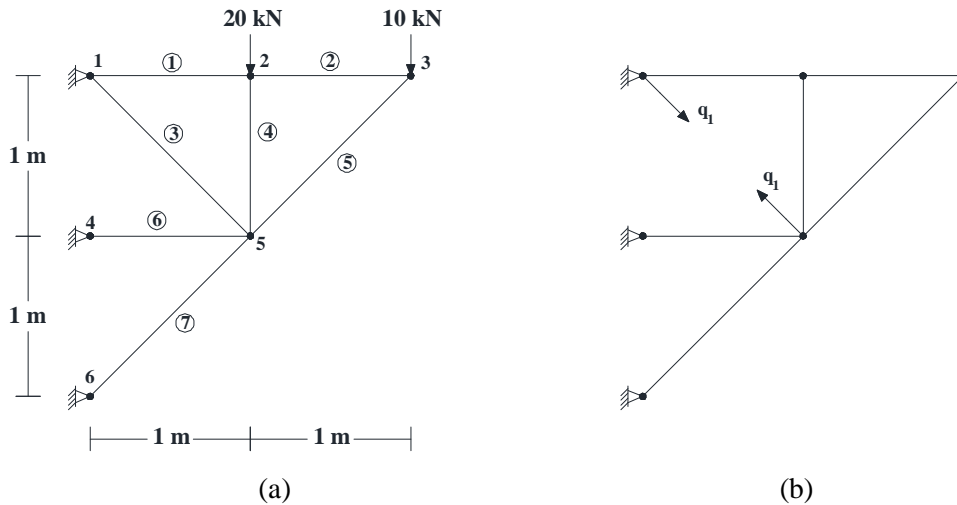

Figure 6. A truss with a single degree of static indeterminacy: (a) A truss; and (b) The selected basic structure

3.2. Example 2

The truss shown in Figure 7 is analyzed using the ant colony algorithm, where the material obeys the Ramberg-Osgood material. Table 1 shows the data needed for Ramberg-Osgood material. This relationship is expressed as

$$\mathbf{e} = \frac{L\mathbf{r}}{EA} \left[1 + \frac{3}{7} \left(\frac{\mathbf{r}}{\sigma_0 A} \right)^{n-1} \right] \rightarrow [\mathbf{F}_i] = \frac{L}{EA} \left[1 + \frac{3}{7} \left(\frac{\mathbf{r}}{\sigma_0 A} \right)^{n-1} \right] \tag{19}$$

This structure is twice statically indeterminate, and the redundant forces are selected as the internal forces of members 2 and 7. $[\mathbf{B}_0]$ and $[\mathbf{B}_1]$ can be written as

$$[\mathbf{B}_0] = \begin{bmatrix} 1.5 \\ 0 \\ -1.25 \\ -0.75 \\ 1 \\ 0.75 \\ 0 \\ -1.25 \\ 0 \\ 1 \end{bmatrix}, \quad [\mathbf{B}_1] = \begin{bmatrix} -0.6 & 0 \\ 1 & 0 \\ 1 & 0 \\ -0.6 & 0 \\ -0.8 & -0.8 \\ 0 & -0.6 \\ 0 & 1 \\ 0 & 1 \\ 0 & -0.6 \\ 0 & -0.8 \end{bmatrix}$$

Substituting the two unknowns, $[\mathbf{B}_0]$ and $[\mathbf{B}_1]$ in Equation (3), all the member forces are calculated and substituted in Equation (19) to obtain the flexibility matrix. AC performs well and leads in $\{\mathbf{r}\} = \{11.250, 6.250, -6.250, -11.250, 0.007, 3.756, 6.240, -6.260, -3.744, 5.008\}^t \text{ K}$ by turning the Equation (17) into zero selecting 20 ants and in 20 iterations where $\{\mathbf{r}\} = \{11.250, 6.250, -6.250, -11.250, -0.045, 3.716, 6.306, -6.194, -3.784, 4.955\}^t \text{ K}$ obtained from GA (Ref. [1]).

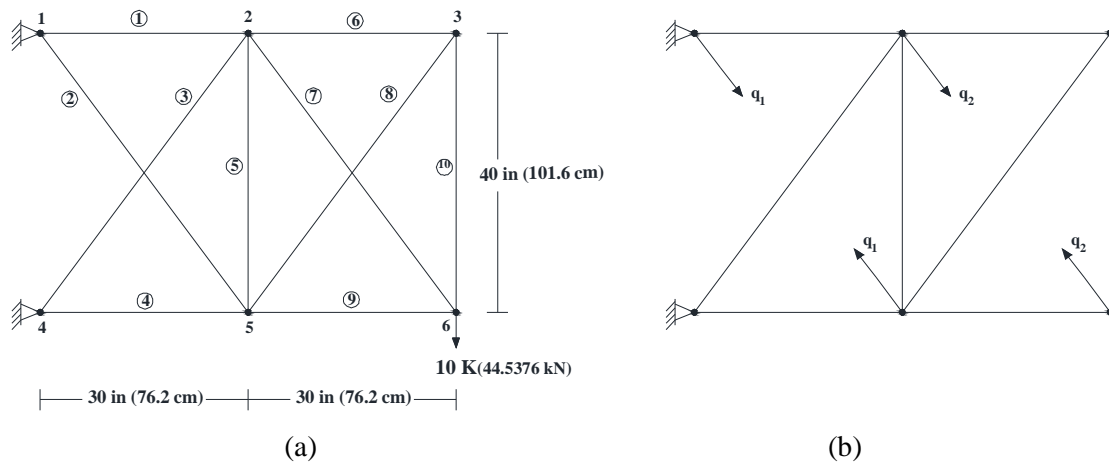

Figure 7. A planner truss with two degrees of static indeterminacy: (a) A truss; and (b) The selected basic structure

Table 1. Parameters corresponding to Ramberg-Osgood

Members	L: in. (cm)	A: in ² (cm ²)	S ₀ : ksi (MPa)	n
1,4,6,9	30 (76.2)	0.25 (1.6129)	10.13 (69.7957)	7
2,3,7,8	50 (127)	0.20 (1.2903)	8.10 (55.8090)	7
5,10	40 (101.6)	0.20 (1.2903)	8.10 (55.8090)	7

4. GEOMETRIC NONLINEAR ANALYSIS USING ANT COLONY ALGORITHM

In this section, the geometric nonlinearity is added to the material nonlinearity. Geometric nonlinear effects need to be simulated when stiffness properties or loads change significantly as the result of deformation. Rigorous analysis of geometrically nonlinear structures demands creating mathematical models that accurately include loading and support conditions and, more importantly, model the stiffness (or flexibility) and response of the structure. Analysis of snap-through buckling is an example in which geometric nonlinearity effects are important. In this paper, we employ the ant colony algorithm instead of solving complicated mathematical models.

In geometric nonlinearity, problem involves variable displacements in each step, therefore considering the redundant forces as the unknowns is not sufficient since the displacements are independent of the unknown forces and are also dependent on the forces of the other members. Thus in each step, \mathbf{B}_0 and \mathbf{B}_1 matrices will be functions of displacements and are not unchanged as in the previous cases. Therefore, apart from redundant forces, the nodal displacements of the structure should also be considered as the unknown parameters of the ant colony algorithm.

One can use complementary energy function as the goal function of AC to perform geometric nonlinear analysis. In this iterative method, \mathbf{B}_0 and \mathbf{B}_1 can be calculated in each step, and operations similar to the previous algorithm should be repeated.

It will be beneficial if only nodal displacements are used as unknowns and the redundant forces are eliminated. When the system is in equilibrium, the total potential energy (\mathbf{V}) of the structure is minimum; therefore we use \mathbf{V} in place of U^c in AC algorithm. This process consists of the following steps:

Step 1: Selecting each \mathbf{u} (nodal displacements vector), the elongations of the elements are obtained as $\mathbf{d}=\mathbf{E}^t\mathbf{u}$. In this equation \mathbf{E} is the compatibility matrix and its transpose is the equilibrium matrix as $\mathbf{E}=\mathbf{B}^t$. It should be noted that \mathbf{E} is a function of \mathbf{u} and it is calculable in terms of \mathbf{u} . Alternatively, in truss structures one can use the following simple relations to calculate the elongations of an element.

$$L_1 = \sqrt{(x_i - x_j)^2 + (y_i - y_j)^2}$$

$$L_2 = \sqrt{(x_i - x_j + u_i - u_j)^2 + (y_i - y_j + v_i - v_j)^2} \quad (20)$$

$$\Delta L = L_2 - L_1$$

Where $u_{i,j}$ and $v_{i,j}$ are the nodal displacements in the X and Y directions.

Step 2: Calculate $\epsilon = d/L$ ($\Delta L/L$) and then obtain the $\sigma = g(\epsilon)$. Here g can be linear or nonlinear.

Step 3: To satisfy the equilibrium condition, minimize the potential energy of the structure by the ant colony algorithm that can be written as

$$\mathbf{V} = \int_V e(\boldsymbol{\varepsilon}) dV - \sum_1^n \mathbf{P}_i \mathbf{u}_i \quad (21)$$

where \mathbf{V} is the potential energy, V is the volume of the body and

$$e(\boldsymbol{\varepsilon}) = \int_0^{\boldsymbol{\varepsilon}} \boldsymbol{\sigma}(\boldsymbol{\varepsilon}) d\boldsymbol{\varepsilon} \quad (22)$$

For a truss structure, Equation (21) can be modified as

$$\mathbf{V} = \sum_{i=1}^m e_i A_i L_i - \sum_{i=1}^n \mathbf{P}_i \mathbf{u}_i \quad (23)$$

4.1. Example 1

Consider the truss shown in Figure 8 from Refs. [1, 8]. In this truss, the cross-sectional areas for the members 2-4 are 100 mm^2 and the remaining members are 200 mm^2 . This example is studied with linear and nonlinear material considering the geometric nonlinearity. For linear case, $E = 2 \times 10^5 \text{ MPa}$ and for the nonlinear material, stress-strain curve is represented as

$$\boldsymbol{\sigma} = \begin{cases} 2 \times 10^5 \boldsymbol{\varepsilon} & 0 < \boldsymbol{\varepsilon} < 0.002 \\ 10^5 \boldsymbol{\varepsilon} + 200 & 0.002 < \boldsymbol{\varepsilon} < 0.004 \\ 0.5 \times 10^5 \boldsymbol{\varepsilon} + 400 & 0.004 < \boldsymbol{\varepsilon} \end{cases} \quad (24)$$

where $\boldsymbol{\sigma}$ is measured in MPa.

The results are given in Table 2 and compared. Though this method is quite straight forward, however, it is only suitable for structures with low kinematic indeterminacy, since the unknown corresponding to the degrees of freedom (DOFs) are the parameters of AC. In the previous example, the horizontal and vertical displacements (u and v) of the nodes 4 and 5 (only four variables) were selected as the unknowns of the goal function.

In what follows, a method is presented which can be considered as a combination of the force method and the displacement approach. In this method, the unknowns of the AC are the redundant forces; however, the objective function is selected as the total potential energy from the displacement method. After selecting the redundants with assuming constant geometry, other forces are calculated. These displacements result in the nodal displacements used for the evaluation of the total potential energy. In a subsequent step, the same process is repeated with the difference of employing the new vector \mathbf{u} in place of the constant geometry.

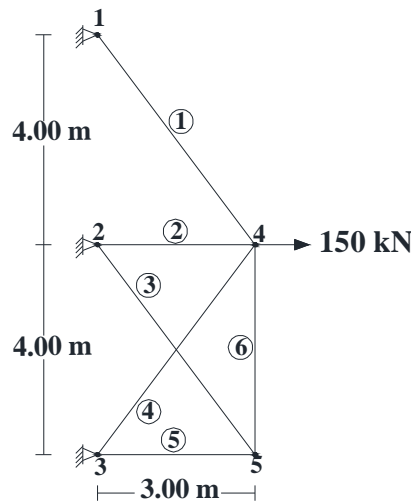

Figure 8. A six-bar planner truss

Table 2. The results of geometric nonlinear analysis for linear and nonlinear material

Material	Method	Potential energy (kN-m)	Nodal displacement (mm)				Member forces (kN)					
			u ₄	v ₄	u ₅	v ₅	r ₁	r ₂	r ₃	r ₄	r ₅	r ₆
Linear	Ref. [1]	-1.0560	-	-	-	-	51.015	94.1406	-6.5528	42.0295	3.9638	5.2843
	Ref. [8]	-1.059735	14.12	2.83	0.30	2.32	49.811	94.142	-6.688	42.974	4.035	5.352
	Peresent work (AC)	-1.0597	14.12	2.83	0.30	2.32	49.811	94.142	-6.688	42.974	4.035	5.352
Nonlinear	Ref. [1]	-11.2614	-	-	-	-	50.2482	93.2042	-7.1814	41.921	4.5218	5.7016
	Ref. [8]	-11.27096	139.71	28.46	3.30	25.00	50.163	93.190	-7.195	41.494	4.535	5.782
	Present work (AC)	-11.271	139.71	28.46	3.30	25.00	50.163	93.190	-7.195	41.494	4.535	5.782

The algorithm consists of the following steps:

1. $\mathbf{u}^{(1)} = 0$ is considered and the redundant force are taken as the parameters of the AC ($i = 1$).
2. Having $\mathbf{u}^{(i)}$; the matrices $\mathbf{B}_0^{(i)}$, $\mathbf{B}_1^{(i)}$ and $\mathbf{E}^{(i)}$ are constructed.
3. Having cross sections of the members, the internal forces and stresses are calculated.
4. Having the stresses, the strains is calculated using stress-strain relationship ($\epsilon^{(i)} = f(\sigma^{(i)})$, and then $\mathbf{d}^{(i)}$ (elongation of members) is formed.
5. Forming $\mathbf{d}^{(i)} = \mathbf{E}^{(i)t} \mathbf{u}^{(i)}$ and considering that $\mathbf{E}^{(i)t}$ is a function of $\mathbf{u}^{(i-1)}$, a suitable $\mathbf{u}^{(i)}$ is selected.
6. The magnitude of \mathbf{V} is then calculated from Equation (21).
7. Putting $i = i + 1$ and going to Step 2, the process is repeated until \mathbf{V} is minimized.

4.2. Example 2

Consider a truss with 31 members as shown in Figure 9. This truss has 6 bays which has been

studied in Refs. [1,8,9]. The stress-strain relationship is considered to be bilinear as

$$E = \begin{cases} 2.00 \times 10^6 \text{ kg/cm}^2 (19.6 \times 10^4 \text{ MPa}) & 0 < \sigma < 2000 \text{ kg/cm}^2 (196 \text{ MPa}) \\ 0.1 \times 10^6 \text{ kg/cm}^2 (0.98 \times 10^4 \text{ MPa}) & \sigma > 2000 \text{ kg/cm}^2 (196 \text{ MPa}) \end{cases} \quad (25)$$

Because of the high degree of static indeterminacy, the first method is not efficient, and therefore the second approach is adopted. The internal forces in 6 bars are taken as the AC unknowns. Table 3 contains the results of AC and those of the existing references for comparison.

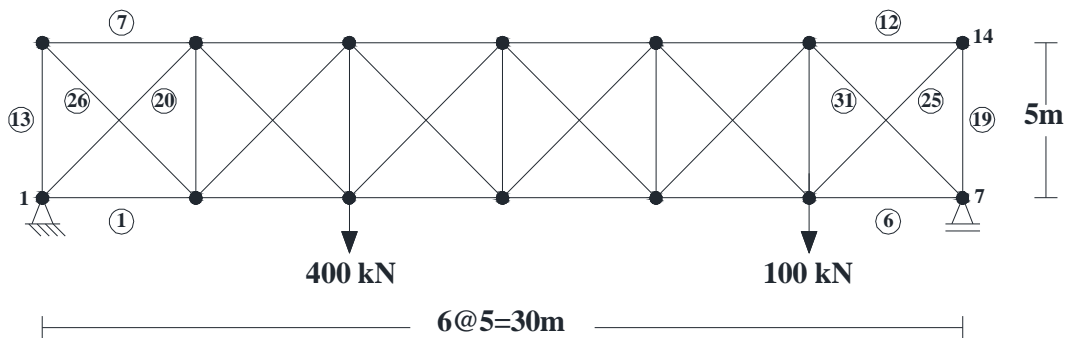

Figure 9. Geometry and numbering of 31-member truss

Table 3. The results of geometric nonlinear analysis of the 31-bar truss

Method	Member forces (ton) an (kN)									
	r_2 ton (kN)	r_3 ton (kN)	r_4 ton (kN)	r_5 ton (kN)	r_8 ton (kN)	r_9 ton (kN)	r_{10} ton (kN)	r_{11} ton (kN)	r_{20} ton (kN)	r_{27} ton (kN)
Ref. [1]	441.71 (4328.8)	515.42 (5051.1)	397.51 (3895.6)	277.82 (2722.6)	-429.81 (-4212)	-501.74 (-4917)	-385.42 (-3777)	-277.11 (-2716)	-203.18 (-1991)	202.91 (1988.5)
Ref. [8]	442.8 (4339.4)	514.8 (5045.0)	397.6 (3896.5)	278.1 (2725.4)	-430.7 (-4221)	-504.8 (-4947)	-389.9 (-3821)	-278.0 (-2724)	-203.0 (-1989)	204.7 (2006.1)
Ref. [9]	443.11 (4342.5)	512.61 (5023.6)	397.82 (3898.6)	278.61 (2730.4)	-431.67 (-4230)	-509.98 (-4998)	-392.08 (-3842)	-278.49 (-2729)	-202.72 (-1987)	206.15 (2020.3)
Present work (AC)	442.7 (4338.7)	514.6 (5043.3)	397.6 (3896.7)	278.2 (2726.5)	-431.1 (-4225.0)	-503.6 (-4935.5)	-389.2 (-3814.4)	-277.8 (-2722.6)	-203.0 (-1989.5)	205.2 (2011.1)

5. ANT COLONY ALGORITHM FOR SIMULTANEOUS ANALYSIS AND DESIGN

Common methods for designing structures usually involve two separate processes; analysis and design. In these classical methods, usually, first a preliminary design is performed, and an analysis is then carried out, followed by design of members. In the next step, the new structure is analyzed and designed. This process is repeated until an acceptable design is obtained and all the requirements are met. For each member, the stress ratio c_i obtained by dividing the stress resultants to the admissible stress, is not greater than unity. Most of computer programs use this method for designing the structures. Here, a method is presented which performs the analysis and design process simultaneously by employing only one function that contains all of requirements for analysis and design that leads to lesser calculation and run time. For this purpose, the stress ratios of members are specified in the onset of simultaneous analysis and design (SAND) process. One may choose to design which makes full usage of the capacity of the members (FSD). This happens when the stress ratios c_i of the members become equal to unity. A classical design hardly ever leads to a design in which, the full capacity of all members are used and some members will have additional free capacity. In some designs, however, it is ideal to have specified additional capacity for certain members. Here, choosing each ant \mathbf{q} , \mathbf{r} is calculated. Knowing the permissible stress, the suitable cross-sections can be selected. As an example, one can choose the section such that it corresponds to a specified stress ratio. This problem is of importance in seismic design of frames, where strong column design is preferred. The method is clarified by the following examples accompanying the required formulations.

5.1. Example 1

Here, we want to design the truss shown in Figure 7 with new analysis goal function using AC. Redundant forces consist of two internal forces denoted by q_1 and q_2 . The complementary energy of the structure should be minimized for analysis by the force method.

If the cross sections A_i ($i=1, \dots, m$) are known, then the analysis can be performed using the ant colony algorithm as described in the previous section. Since the main aim is to design, one can obtain cross-sections A corresponding to the selected values of q (for each ant). U^c can be calculated as

$$U^c = \frac{1}{2} \{\mathbf{r}\}^t [\mathbf{F}_m] \{\mathbf{r}\} \quad (26)$$

$$\{\mathbf{r}\} = [\mathbf{B}_0 \quad \mathbf{B}_1] \begin{bmatrix} \mathbf{p} \\ \mathbf{q} \end{bmatrix} \quad (27)$$

For a truss member with linear material, $F_m = L/EA$ and for each selected ant (q), one can obtain $\{\mathbf{r}\}$ from Equation (27), and each r corresponds to a set of cross-sectional areas (A), the entries of which appear in the denominator of \mathbf{F}_m . Therefore, \mathbf{F}_m is a function of L , E , q and c (i.e. A is eliminated). Thus U^c is a function of \mathbf{q} and \mathbf{c} only. The pre-selected entries for c may be imposed at this stage. The role of c in finding A in terms of q has thus been shown,

and U^c can easily be minimized by the ant colony algorithm. U^c should be minimized in which $[F_m]$ is a function of the unknowns \mathbf{q} , \mathbf{c} , L and E as

$$[F_m] = \frac{L}{EA} = \frac{L}{E \mathbf{f}(\mathbf{r}, L, \mathbf{c})} = \mathbf{g}(\mathbf{q}, \mathbf{c}, L, E) \quad (28)$$

Now we introduce a goal function for truss structures for the purpose of minimization using ant colony with minimum parameters.

$$c_i = \frac{ABS(r_i)}{A_i \sigma_{ai}} \quad ABS: \text{Absolute Value} \quad (29)$$

$$A_i = \frac{ABS(r_i)}{c_i \sigma_{ai}} \quad (30)$$

From Equations (28) and (30), for each member we have

$$F_{mi} = \frac{L_i c_i \sigma_{ai}}{E_i \cdot ABS(r_i)} \quad (31)$$

$$U_i^c = \frac{1}{2} r_i F_{mi} r_i \quad (32)$$

Substituting F_{mi} from Equation (31) into Equation (32) leads to

$$U_i^c = \frac{1}{2} r_i \frac{L_i c_i \sigma_{ai}}{E_i} \lambda_i \quad \left(I_i = \frac{ABS(r_i)}{r_i} \right) \quad (33)$$

$$U^c = \frac{1}{2} \{\mathbf{r}\}^t \begin{bmatrix} \frac{L_1 c_1 \sigma_{a1}}{E_1} & 0 & \mathbf{L} & 0 \\ 0 & \frac{L_2 c_2 \sigma_{a2}}{E_2} & \mathbf{K} & 0 \\ \mathbf{M} & \mathbf{M} & \mathbf{O} & 0 \\ 0 & 0 & 0 & \frac{L_m c_m \sigma_{am}}{E_m} \end{bmatrix} \begin{Bmatrix} \lambda_1 \\ \mathbf{M} \\ \mathbf{M} \\ \lambda_m \end{Bmatrix} \quad (34)$$

$$F_U = \{\mathbf{r}\}^t \begin{bmatrix} \frac{L_1 c_1 \sigma_{a1}}{E_1} & 0 & \mathbf{L} & 0 \\ 0 & \frac{L_2 c_2 \sigma_{a2}}{E_2} & \mathbf{K} & 0 \\ \mathbf{M} & \mathbf{M} & \mathbf{O} & 0 \\ 0 & 0 & 0 & \frac{L_m c_m \sigma_{am}}{E_m} \end{bmatrix} \begin{Bmatrix} \lambda_1 \\ \mathbf{M} \\ \mathbf{M} \\ \lambda_m \end{Bmatrix} \quad (35)$$

σ_{ai} is the maximal allowable stress for each member. Suppose σ_a and E are constants for all members, then the goal function can be written as

$$F_U = \{\mathbf{r}\}^t \begin{bmatrix} Lc_1 & 0 & \mathbf{L} & 0 \\ 0 & Lc_2 & \mathbf{K} & 0 \\ \mathbf{M} & \mathbf{M} & \mathbf{O} & 0 \\ 0 & 0 & 0 & L_m c_m \end{bmatrix} \begin{Bmatrix} \lambda_j \\ \mathbf{M} \\ \mathbf{M} \\ \lambda_m \end{Bmatrix} \quad (36)$$

In this study, F_u is minimized by ant colony algorithm. For the introduced functions, $\{\mathbf{q}\}$ is unknown and L_i, c_i, σ_{ai} and E_i are specified for each member. Suppose ignoring the buckling effect, we want to have the stress ratio 0.8 for the members and 25 ksi (172.375 Pa) for the allowable stress. Application of the present method leads to some cross-section with nearly zero area. In this case, $A_{\min} = 0.01 \text{ in}^2$ (0.0645 cm^2) is selected. The calculation of this example performed by AC using 30 ants and in 25 iterations. Results are presented in Table 4. The results obtained from GA in Ref. [1], are also provided for comparison in Table 4.

Table 4. Results for the 10-bar planar truss

AC
$\{\mathbf{q}\} = \{0.037, 12.370\}^t \text{ k}$
$\{\mathbf{q}\} = \{0.165, 55.093\}^t \text{ kN}$
$\{\mathbf{r}\} = \{14.9778, 0.0370, -12.4630, -7.5222, 0.0744, 0.0780, 12.3700, -0.1300, -7.4220, 0.1040\}^t \text{ K}$
$\{\mathbf{r}\} = \{66.7075, 0.1648, -55.5072, -33.5021, 0.3314, 0.3474, 55.0930, -0.5790, -33.0558, 0.4632\}^t \text{ kN}$
$A = \{0.7489, 0.01, 0.6231, 0.3761, 0.01, 0.01, 0.6185, 0.01, 0.3711, 0.01\} \text{ in}^2$
$A = \{4.8316, 0.0645, 4.0200, 2.4264, 0.0645, 0.0645, 3.9903, 0.0645, 2.3942, 0.0645\} \text{ cm}^2$
GA [1]
$\{\mathbf{q}\} = \{0.2, 12.301\}^t \text{ k}$
$\{\mathbf{q}\} = \{0.8891, 54.6826\}^t \text{ kN}$
$\{\mathbf{r}\} = \{14.88, 0.2, -12.3, -7.62, -0.001, 0.119, 12.301, -0.199, -7.381, 0.159\}^t \text{ K}$
$\{\mathbf{r}\} = \{66.1472, 0.8891, -54.6781, -33.8738, -0.0044, 0.5290, 54.6826, -0.8846, -32.8113, 0.7068\}^t \text{ kN}$
$A = \{0.7440, 0.01, 0.6150, 0.3810, 0.01, 0.01, 0.6151, 0.01, 0.3690, 0.01\} \text{ in}^2$
$A = \{4.80, 0.0645, 3.9677, 2.4581, 0.0645, 0.0645, 3.9684, 0.0645, 2.3806, 0.0645\} \text{ cm}^2$

5.2. Example 2

A 25-bar truss is shown in Figure 10. Table 5 contains the data for design of this truss. Table 6 provides the results obtained from AC and GA [1]. Comparison between ant colony and genetic algorithms shows that AC performs better for SAND.

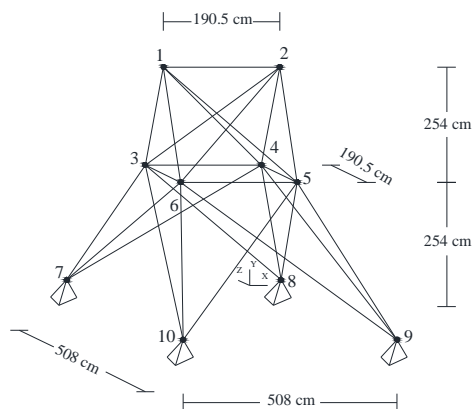

Figure 10. A 25-bar space truss

Table 5. Data for design of the 25-bar space truss.

Member number	Start point (i)	End point (j)	Length (cm)
1	1	2	190.5
2	1	4	331.48
3	2	3	331.48
4	1	5	331.48
5	2	6	331.48
6	2	4	271.27
7	2	5	271.27
8	1	3	271.27
9	1	6	271.27
10	3	6	190.5
11	4	5	190.5
12	3	4	190.5
13	5	6	190.5
14	3	10	460.10
15	6	7	460.10
16	4	9	460.10
17	5	8	460.10
18	4	7	460.10
19	3	8	460.10
20	5	10	460.10
21	6	9	460.10
22	6	10	339.00
23	3	7	339.00
24	5	9	339.00
25	4	8	339.00

Stress constraints

$|\sigma_i| \leq 40 \text{ ksi (275.8MPa)}; i = 1, \dots, 25$
 $c_i = 1; i = 1, \dots, 25$

List of the available profiles

$A_i \geq 0.01 \text{ in}^2 (0.06452 \text{ cm}^2); i = 1, \dots, 25$

Loading data

Node	P_x : kips (kN)	P_y : kips (kN)	P_z : kips (kN)
1	1(4.448)	-10 (44.48)	-10 (44.48)
2	0	-10 (44.48)	-10 (44.48)
3	0.5(2.224)	0	0
6	0.6(2.6688)	0	0

Table 6. Design comparison for the 25-bar truss

AC
{A}={0.0266, 0.01, 0.01, 0.01, 0.539, 0.1782, 0.4833, 0.4880, 0.2188, 0.01, 0.01, 0.2811, 0.1025, 0.1055, 0.0535, 0.1012, 0.0406, 0.0145, 0.01, 0.01, 0.019, 0.5288, 0.5302, 0.1962, 0.2843} in ²
{A}={0.1716, 0.0645, 0.0645, 0.0645, 3.4774, 1.1497, 3.1181, 3.1484, 1.4116, 0.0645, 0.0645, 1.8135, 0.6613, 0.6806, 0.3452, 0.6529, 0.2619, 0.0935, 0.0645, 0.0645, 0.1226, 3.4116, 3.4206, 1.2658, 1.8342} cm ²
GA [1]
{A}={0.0265, 0.01, 0.01, 0.01, 0.0539, 0.1784, 0.4831, 0.4880, 0.2189, 0.01, 0.01, 0.2813, 0.1019, 0.1056, 0.0550, 0.1007, 0.0406, 0.0145, 0.01, 0.01, 0.021, 0.5294, 0.5305, 0.1962, 0.2842} in ²
{A}={0.1710, 0.0645, 0.0645, 0.0645, 0.3477, 1.1510, 3.1168, 3.1484, 1.4123, 0.0645, 0.0645, 1.8148, 0.6574, 0.6813, 0.3548, 0.6497, 0.2619, 0.0935, 0.0645, 0.0645, 0.1355, 3.4155, 3.4226, 1.2658, 1.8335} cm ²

5.3. Example 3

Consider the planner truss studied in section (3.2). Here, the main aim is to show the capability of present method and ant colony algorithm in the nonlinear design of structures. The allowable stress is selected as $\sigma_a = 21$ ksi (144.795 MPa). Because of the nonlinearity, Equation (35) can not be used as the goal function of minimization and complementary energy function (Equation (26)) is selected in this case. Table 7 contains the results obtained from AC with $c_i=1$ for all members.

Table 7. Design for the 10-bar truss with nonlinear material.

{r} = {14.8230, 0.2949, -12.2051, -7.6770, -0.2293, 0.0050, 12.4918, -0.0083, -7.4950, 0.0066} k
{r} = {66.0180, 1.3135, -54.3583, -34.1911, -1.0214, 0.0220, 55.6350, -0.0367, -33.3810, 0.0294} kN
{A} = {0.7059, 0.0140, 0.5812, 0.3656, 0.0109, 0.0002, 0.5948, 0.0004, 0.3569, 0.0003} in ²
{A} = {4.5539, 0.0906, 3.7496, 2.3585, 0.0705, 0.0015, 3.8377, 0.0025, 2.3026, 0.0020} cm ²

6. OPTIMAL DESIGN USING ANT COLONY ALGORITHM

Since the material cost is one of the major factors in the construction of a building, it is preferable to reduce it by minimizing the weight or volume of the structural system. All of the methods used for minimizing the volume or weight intend to achieve an optimum design having a set of design variables under certain design criteria. In the present method, adding the weight term next to the energy term leads in a new goal function for ant colony algorithm. By minimizing this function a set of cross sections is obtained for the members of the structure with minimum weight and minimum complementary energy satisfying the compatibility.

Other design constraints like buckling, displacement, stress, etc. can be added to the goal function using a penalty coefficient that can be expressed as

$$\text{Find } (\mathbf{q}, A); A \in \{S_d, S_c\} \quad \mathbf{W}(A) = \sum_{i=1}^M A_i L_i \rho_i$$

$$\text{Min } F(\mathbf{q}, A) = \mathbf{W}(A)(1 + \alpha \text{norm}([\mathbf{H}_{qp}] \{\mathbf{p}\} + [\mathbf{H}_{qq}] \{\mathbf{q}\})) + \sum_{m=1}^{nc} \max[0, \mathbf{g}_m(A)] \quad (37)$$

Where S_d and S_c are the discrete and continuous cross sections, respectively. $\mathbf{g}_m(A)$ corresponds to the violations of constraints, which include stress, displacement and buckling constraints. Their magnitudes can be written in the form of the absolute value of existing value to permissible value minus one.

In order to show the capability of the method using the ant colony algorithm, a truss and a frame structure are studied in the following examples.

6.1. Example 1: A 10-bar planar truss

Optimal design of a 10-bar truss, as shown in Figure 11, is considered. Table 8 contains the necessary data. Here, a displacement constraint is added (Table 5). In this example, two cases are considered, the first is for discrete and the second corresponds to continuous sections. In both cases, A and q are design variables, but in discrete case, we employed a code for sections. Using the formulation of the previous section and minimizing the Equation (37), the results provided in Tables 9 and 10 are obtained.

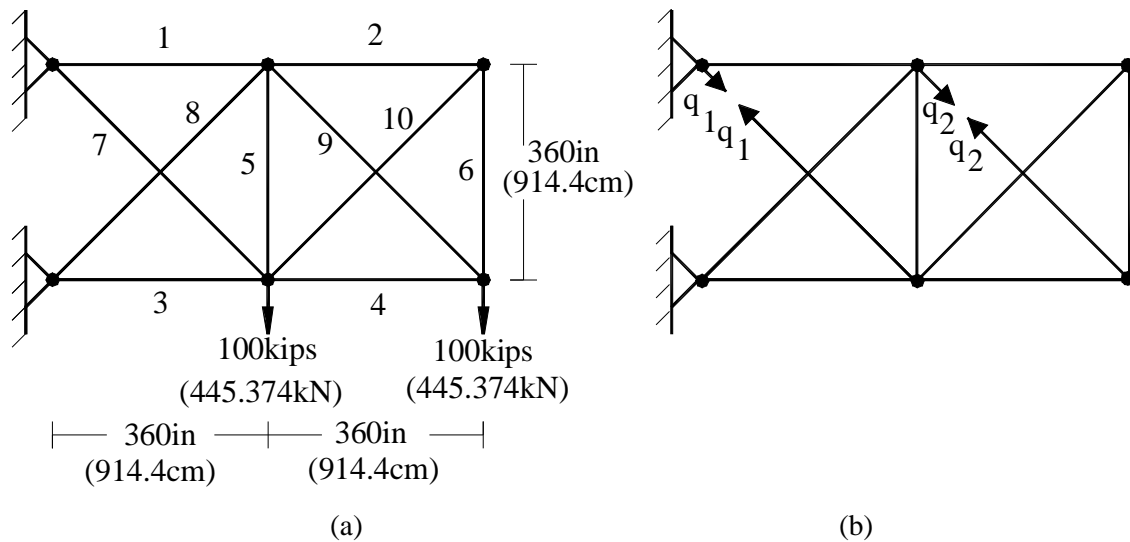

Figure 11. A simple truss and its loading: (a) A planar truss; (b) The selected basic structure

Table 8. Design data for the 10-bar planar truss.

Material property and constraint data	
Young's modulus: $E = 1e7 \text{ psi} = 6.895e7 \text{ MPa}$.	
Density of the material: $\rho = 0.00277 \text{ kg/cm}^3 = 0.1 \text{ lb/in}^3$	
Stress constraints	
$ \sigma_i \leq 25 \text{ ksi} (172.375 \text{ MPa}); \quad i = 1, \dots, 10$	
Nodal displacement constraint in all directions of the co-ordinate system	
$ \sigma_i \leq 2 \text{ in} (5.08 \text{ cm}); \quad i = 1, \dots, 4$	
List of the available profiles	
Case 1: (Discrete sections)	
$A_i = \{1.62, 1.80, 1.99, 2.13, 2.38, 2.62, 2.63, 2.88, 2.93, 3.09, 3.13, 3.38, 3.47, 3.55, 3.63, 3.84, 3.87, 3.88, 4.18, 4.22, 4.49, 4.59, 4.80, 4.97, 5.12, 5.74, 7.22, 7.97, 11.5, 13.5, 13.9, 14.2, 15.5, 16.0, 16.9, 18.8, 19.9, 22.0, 22.9, 26.5, 30.0, 33.5\} \text{ in}^2$	
$A_i = \{10.4516, 11.6129, 12.8387, 13.7419, 15.3548, 16.9032, 16.9677, 18.5806, 18.9032, 19.9354, 20.1935, 21.8064, 22.3871, 22.9032, 23.4193, 24.7741, 24.9677, 25.0322, 26.9677, 27.2258, 28.9677, 29.6128, 30.9677, 32.0645, 33.0322, 37.0322, 46.5806, 51.4193, 74.1934, 87.0966, 89.6772, 91.6127, 99.9998, 103.2256, 109.0320, 121.2901, 128.3868, 141.9352, 147.7416, 170.9674, 193.5480, 216.1286\} \text{ cm}^2$	
Case 2: (Continuous sections) $0.1 \leq A_i \leq 35 \text{ in}^2 (225.8960) \text{ cm}^2; \quad i = 1, \dots, 10$	

Table 9. Optimal design comparison for the 10-bar planar truss (discrete).

Method	Weight: lb (kN)	A_1	A_2	A_3	A_4	A_5	A_6	A_7	A_8	A_9	A_{10}
Kaveh and Rahami [2]	5490.738 (24.4228)	33.5	1.62	22.90	14.2	1.62	1.62	7.97	22.9	22.00	1.62
Shih [10]	5491.71 (24.4271)	33.50	1.62	22.90	15.50	1.62	1.62	7.97	22.00	22.00	1.62
Rajeev [11]	5613.84 (24.9704)	33.50	1.62	22.90	15.50	1.62	1.62	14.20	19.90	19.90	2.62
Present work	5517.72 (24.5702)	33.50	1.62	22.90	14.2	1.62	1.62	11.5	22.00	19.90	1.62

6.2. Example 2: A 25-member frame

Consider the 25-member frame as shown in Figure 12. This frame is designed using the data provided in Table 11, considering both flexural and axial complementary energy and satisfying the stress and displacement constraints. Table 12 contains the results obtained from the present work and other approaches for comparison.

Table 10. Optimal design comparison for the 10-bar planar truss (continuous)

Method	Weight: lb (kN)	A_1	A_2	A_3	A_4	A_5	A_6	A_7	A_8	A_9	A_{10}
Kaveh and Rahami [2]	5061.90 (22.5153)	30.67	0.1	22.87	15.34	0.1	0.46	7.48	20.96	21.70	0.1
Schmit and Farshi [12]	5089.0 (22.6359)	33.43	0.1	24.26	14.26	0.1	0.1	8.39	20.74	19.69	0.1
Schmit and Miura [13]	5076.85 (22.5818)	30.67	0.1	23.76	14.59	0.1	0.1	8.59	21.07	20.96	0.1
Venkayya [14]	5084.9 (22.6176)	30.42	0.13	23.41	14.91	0.1	0.1	8.70	21.08	21.08	0.19
Rizzi [15]	5076.66 (22.5810)	30.73	0.1	23.93	14.73	0.1	0.1	8.54	20.95	21.84	0.1
Kha and Willmert [16]	5066.98 (22.5379)	30.98	0.1	24.17	14.81	0.1	0.41	7.547	21.05	20.94	0.1
Present work	5095.46 (22.6899)	30.86	0.1	23.55	15.01	0.1	0.22	7.63	21.65	21.32	0.1

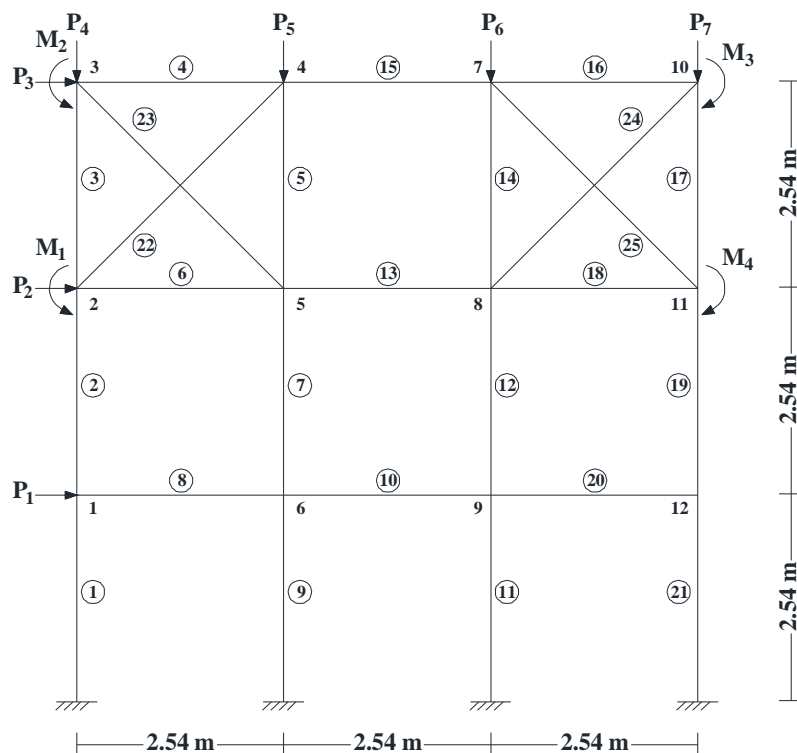

Figure 12. A 25-member frame with 39 degrees of static indeterminacy

Table 11. Design data for the 25-member frame

Material property and constraint data	
Young's modulus: $E = 206844 \text{ MPa}$ (30000000 psi).	
Density of the material: $r = 7830 \text{ kg/m}^3$ (0.283 lbm/in ³).	
Loading properties	
$P_1 = P_2 = P_3 = 444.82 \text{ kN}$	
$P_4 = P_7 = 8896.4 \text{ kN}$	
$P_5 = P_6 = 13344.6 \text{ kN}$	
$M_1 = M_2 = 2259.6856 \text{ kN-m}$	
$M_3 = M_4 = 3389.5284 \text{ kN-m}$	
Stress constraints	
$ \sigma_i \leq 165.4752$ (24000 psi); $i = 1, \dots, 25$ (Combined axial and bending stress)	
Nodal displacement constraint in all directions of the co-ordinate system	
$ D_i \leq 0.0762 \text{ m}$ (0.03 in); $i = 1, 2, 3, 10, 11, 12$	
Design variables	
A_i ; $i = 1, \dots, 25$	
$0.0032258 \leq A_i \text{ m}^2$; $i = 1, \dots, 25$	
Properties of the available profiles	
S(section modules)=9A	
I(moment of inertia)=75A	

Table 12. Optimal design comparison for the 25-member frame

Member number	Method		
	Khan et al. [17]	Wang and Arora [18]	Present work
		A (cm²)	
1	-	832.59	833.44
2	-	978.19	981.35
3	-	977.19	972.33
4	-	198.24	199.20
5	-	852.33	855.19
6	-	32.26	32.26
7	-	842.81	841.14
8	-	150.09	155.23
9	-	1094.97	1089.34
10	-	32.26	32.26
11	-	771.04	769.92
12	-	711.92	715.62
13	-	32.26	32.26
14	-	790.73	791.49
15	-	32.26	32.26
16	-	347.21	342.50
17	-	1225.39	1227.38
18	-	32.26	32.26
19	-	789.39	788.28
20	-	32.26	32.26
21	-	769.71	768.92
22	-	38.88	39.12
23	-	32.26	32.26
24	-	32.26	32.26
25	-	295.01	295.05
		Total volume (m ³)	
	3.070543	3.070543	3.070536

6. CONCLUDING REMARKS

In this article new formulations are presented for linear and nonlinear analyses, considering material and geometric nonlinearity, design and optimization of structures for use in the ant colony algorithms. These methods employ basic ideas from potential and complementary energy and employ a continuous ant colony algorithm. AC performs nonlinear analysis of structures without using the direct solution of equations as required in classical methods. Formulation in terms of energy concepts permits the efficient application of AC in optimization. The present method can easily be adopted for more general structural problems. Beams, frames, plates, shells, volumes can be treated in a similar way. The examples studied in this paper for analysis, design and optimization illustrate the capability and the accuracy of the present methods compared to those of the existing methods.

REFERENCES

1. Kaveh A, Rahami H. Nonlinear analysis and optimal design of structures via force method and genetic algorithm. *Comput Struct* 2006; **84**:770–8.
2. Kaveh A, Rahami H. Analysis, design and optimization of structures using force method and genetic algorithm. *Int J Numer Meth Eng* 2006; **65**(10):1570–84.
3. Chen L, Shen J, Qin L, Fan J. A method for solving optimization problem in continuous space using improved ant colony algorithm. *CASDMKM* 2004; **LNAI 3327**: 61-70.
4. Dorigo M, Stützle T. *Ant Colony Optimization*. The MIT Press: Cambridge, 2004.
5. Socha K. ACO for continuous and mixed-variable optimization. *ANTS 2004*; **LNCS 3172**: 25-36.
6. Pourtakdoust H, Nobari H. An Extension of ant colony system to continuous optimization problems. *ANTS 2004*; **LNCS 3172**: 294-301.
7. Kong M, Tian P. A Direct Application of ant colony optimization to function optimization problem in continuous domain. *ANTS 2006*; **LNCS 4150** : 324-31
8. Toklu YC. Nonlinear analysis of truss through energy minimization. *Comput Struct* 2004; **82**:1581–9.
9. Ohkubo S, Watada Y, Fujiwaki T. Nonlinear analysis of truss by energy minimization. *Comput Struct* 1987; **27**:119–45.
10. Shih CJ, Yang YC. Generalized Hopfield network based structural optimization using sequential unconstrained minimization technique with additional penalty strategy. *Adv Eng Software* 2002; **33**:721–9.
11. Rajeev S, Krishnamoorthy CS. Discrete optimization of structures using genetic algorithms. *J Struct Eng, ASCE* 1992; **118**:1233–50.
12. Schmit Jr LA, Farshi B. Some approximation concepts for structural synthesis. *AIAA J* 1974; **12**: 692–9.
13. Schmit Jr LA, Miura H. Approximation concepts for efficient structural synthesis. NASA CR-2552. *NASA: Washington DC*, 1976.
14. Venkayya VB. Design of optimum structures. *Comput Struct* 1971; **1**:265 –309.
15. Rizzi P. Optimization of multi-constrained structures based on optimality criteria.

AIAA/ASME/SAE 17th Structures, Structural Dynamics, and Materials Conference, King of Prussia, PA, 1976.

16. Khan MR, Willmert KD, Thornton WA. An optimality criterion method for large-scale structures. *AIAA J* 1979; **17**:753–61.
17. Khan MR, Willmert KD, Thornton WA. A new optimality criterion method for large-scale structures. *Proc., AIAA/ASME 19th Structures, Structural Dynamics, and Materials Conference*, Bethesda, Md., 47-50.
18. Wang Q, Arora JS. Alternative formulation for structural optimization: an evaluation using frames. *J Struct Eng, ASCE* 2006; **132**(12):1880-9.